

JOYS ICE BOAT HEADQUARTERS
MEAD FITTINGS
SAILS FOR ALL CLASSES
ICE BOAT PLANS
MARINE HARDWARE

Rope—Nylon, Manila, Linen,
 Cotton • Wire Rope •
 Splicing, Rigging

JOYS BROS. Co.
Sailmakers Since 1844
 129 N. WATER ST., MILWAUKEE 2, WIS. • DAlly 8-0810

JOYS BROS. CO.

NOTICE OF PRICE CHANGES

Page No.	Part No.	Price
1	105	Alum. - 12.50
1	105	Brz. - 14.50
1	120	1.75
2	155	Alum. - .85
2	155	Brz. - 1.30
3	200a	14.00
3	240	1.50
5	310	5.50 - for 60 sq.ft. boat only
5	310a	6.75 - for 75 sq.ft. boat
5	308	2.00 - 5/32" cable for 310
5	308a	2.75 - 3/16" cable for 310a
6	380	.06
6	380a	.05 - safety pin type
6	315	1.40 - long, 8 position
6	315a	1.00 - short, 4 position

TOOL BAGS - 1.50

Zipper closing, heavy canvas.
 Open and close without removing gloves.
 Holds all necessary tools.
 Small parts can't leak out. Will remain open while setting on irregular surfaces.

ICEBOAT PLANS

Simple, easy to follow plans and instructions which will enable you to build an iceboat in your own workshop.

14'	- 2 pass., "Just For Fun" Model	\$ 2.
18'	- Skeeter, 2 Passenger	3.
20'	- Skeeter, Racing Model	5.

Prices Subject To Change Without Notice

JOYS BROS. CO.

FRONT STEERING
RUNNER CHOCK

105 12.50

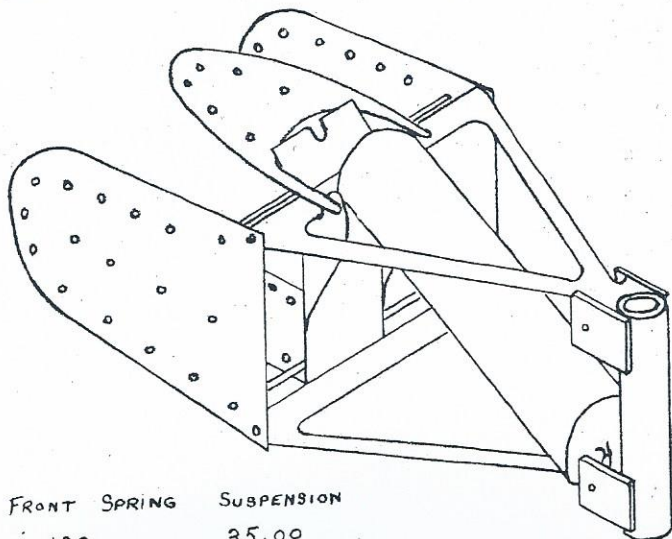
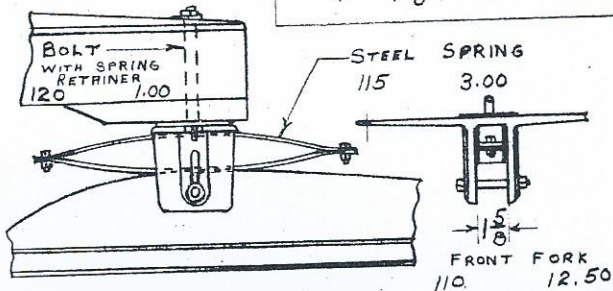
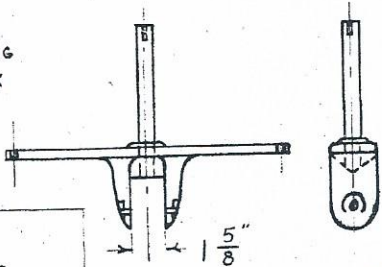

FRONT SPRING SUSPENSION
100 35.00

PRICES SUBJECT TO CHANGE WITHOUT NOTICE

JOYS BROS. CO.

155

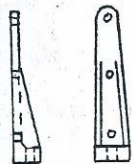

RUNNER PLANK BRKTS.
BRZ. 1.30 EA. - ALUM. 85c

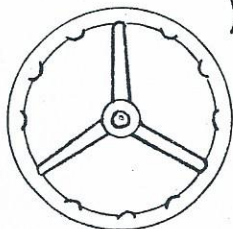

WORM HUB WHEEL
125 ALUM. 4.75 EA

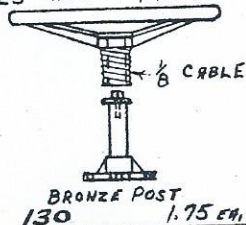

BRONZE POST
130 1.75 EA.

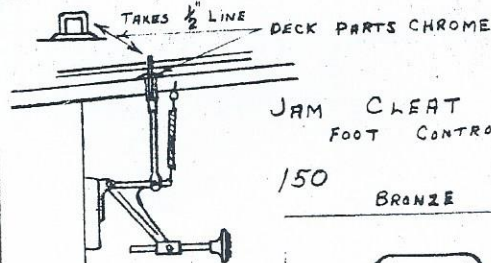

JAM CLEAT
FOOT CONTROLLED
150 BRONZE 7.5

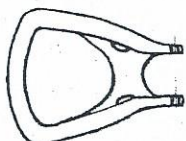

GROOVE TAKES 1/8" CABLE



TILLER
135 1.75 EA.

TILLER POST
145 1.50 EA.



CABLE DRUM
140 2.25 EA.



165
SLIDING BALL KNOB
3.00 EA.

BRONZE

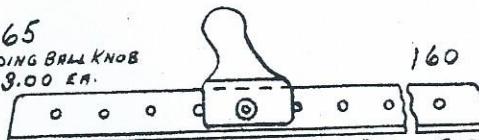

ADJUSTABLE MAST STEP
10.00 COMPLETE

BASE 7.00 EA

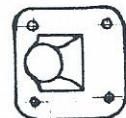

FIXED MAST STEP
170 BRONZE 2.2

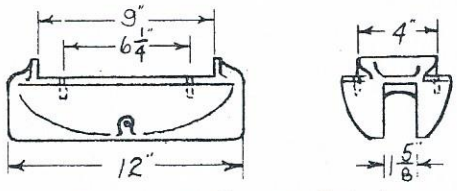
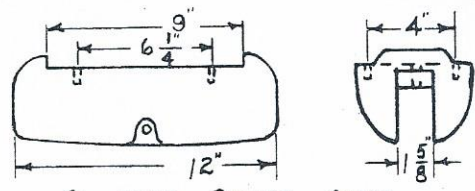
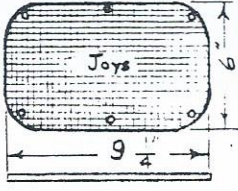
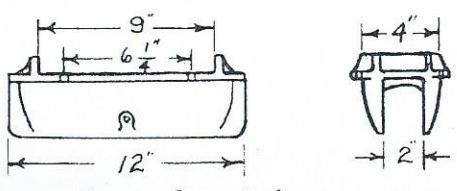
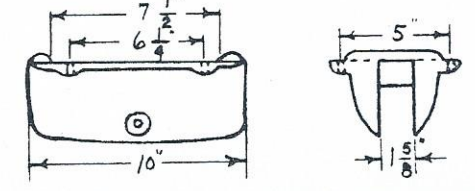
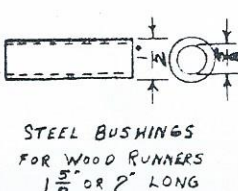

PRICES SUBJECT TO CHANGE WITHOUT NOTICE

JOYS BROS. CO.

 <p>ALUMINUM RUNNER CHOCK FOR RUNNERS $1\frac{5}{8}$" THICK</p> <p>200 10.00 EA</p>	 <p>ALUMINUM RUNNER CHOCK FOR RUNNERS $1\frac{5}{8}$" THICK IMPROVED - HEAT TREATED, HIGH TENSIL</p> <p>200a 12.50 EA</p>	 <p>RUNNER PLANK STEP PLATE</p> <p>240 1.00 EA</p>
 <p>BRONZE RUNNER CHOCK FOR RUNNERS 2" THICK</p> <p>201 12.00 EA</p>	 <p>ALUMINUM RUNNER CHOCK FOR RUNNERS $1\frac{5}{8}$" THICK</p> <p>202 8.50 EA</p>	 <p>STEEL BUSHINGS FOR WOOD RUNNERS $1\frac{5}{8}$" OR 2" LONG</p> <p>230 .15 EA</p>

PRICES SUBJECT TO CHANGE WITHOUT NOTICE

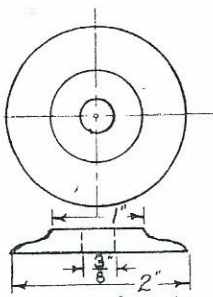
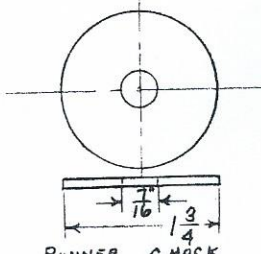
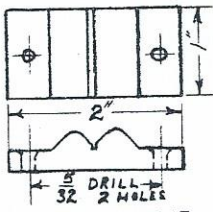
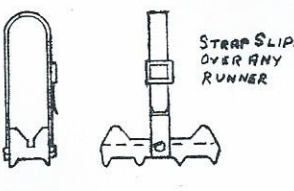
JOYS BROS. CO.

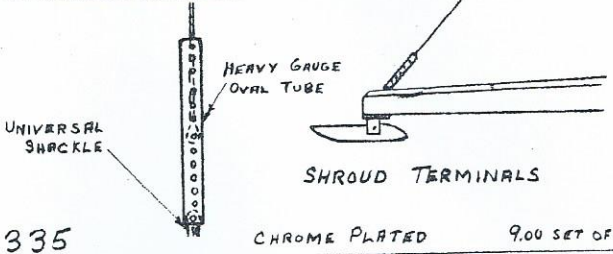
 <p>RUNNER CHOCK BOLT WASHER</p> <p>220 ALUM. .20 EA</p>	 <p>RUNNER CHOCK BOLT WASHER</p> <p>221 STEEL .10 EA</p>	 <p>RUNNER ALIGNMENT STICK GUIDES</p> <p>250 ALUM. .35 EA</p>	 <p>ICE BOAT ANCHOR</p> <p>260 ALUM. 1.00 EA</p>
 <p>FAIRLEADER</p> <p>375 ALUM. .50</p>	 <p>TRAVELLER FOR ROTATING MAST</p> <p>365 BRONZE 1.75 EA</p>	 <p>UNIVERSAL SHACKLE</p> <p>335 CHROME PLATED 9.00 SET OF 3</p>	

PRICES SUBJECT TO CHANGE WITHOUT NOTICE

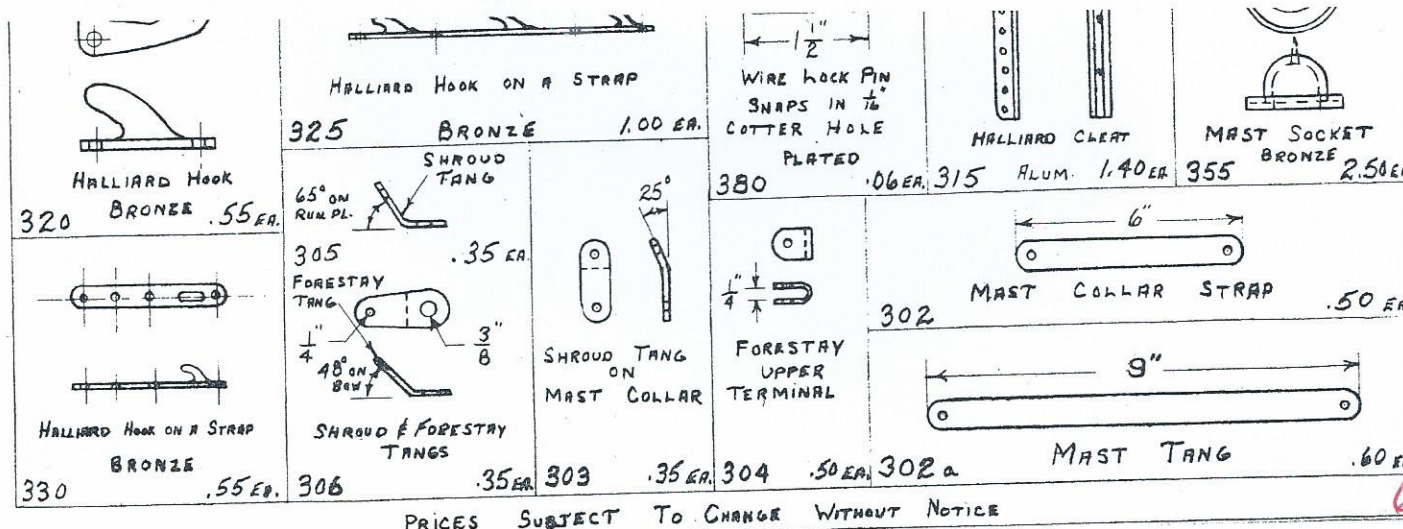
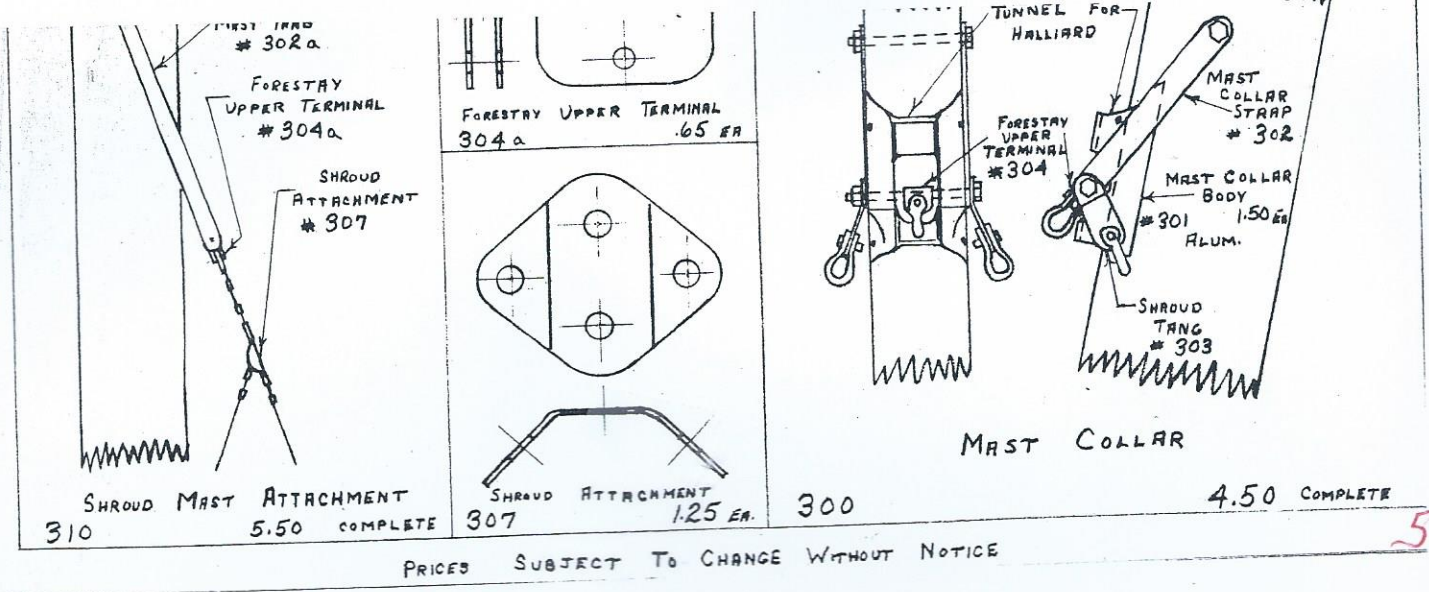

JOYS BROS. CO.

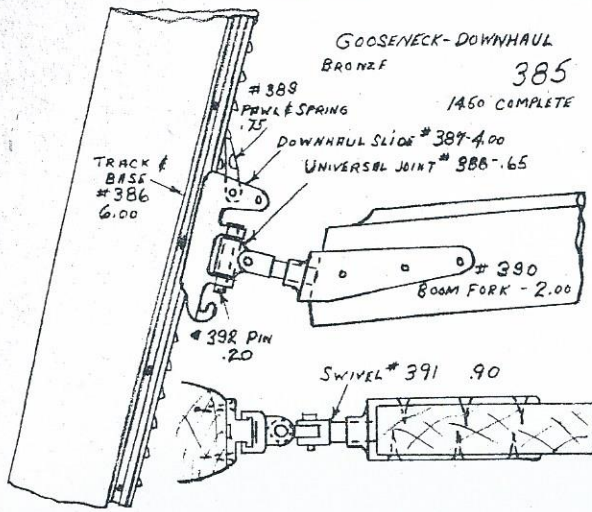

TUNNEL GUARD FOR LOWER END OF MAST TUNNEL ALUM

370 .90 EA.



MASTHEAD CHP

360 1.50 EA.

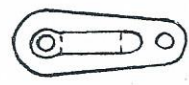

OUTHAUL EYE

350 .40 EA.

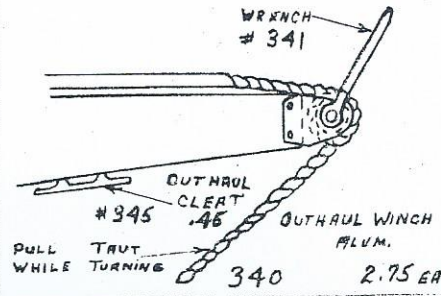

OUTHAUL WINCH ALUM.

340 2.75 EA.

PRICES SUBJECT TO CHANGE WITHOUT NOTICE

JOYS BROS. CO.

ICEBOAT SAIL BATTENS

FULL LENGTH TAPERED SAIL BATTENS OF SELECT ASH. THICKNESS AND TAPER PROPORTIONAL TO LENGTH. SIX HOLES AT THE HEAVY END FOR ADJUSTMENT.

LENGTH	PRICE
3'	\$.75
4'	1.00
5'	1.20
6'	1.45
7'	1.70
8'	1.95
9'	2.25
10'	2.65
12'	3.45

"SAIL ON BOOM" BAGS

ROLL YOUR SAIL AND BATTENS AROUND BOOM. PROTECTS SAIL FROM DIRT, RAIN AND SNOW FULL LENGTH, ZIPPER CLOSING

8.50

RUNNER CASES

TO PROTECT RUNNER EDGES AND FOR EASE IN HANDLING HEAVY CANYONS, FOR THREE RUNNERS

7.50

PRICES SUBJECT TO CHANGE WITHOUT NOTICE

ALL SAILS ARE COMPLETE
WITH ALUMINUM HEADBOARD,
FULL LENGTH BATTEN POCKETS
WITH SNAP FASTENERS AT
LEECH AND LEATHER
REINFORCEMENT AT LUFF,
INSIGNIA AND RACING
NUMBER, AND A SAILBAG.

CLASS E SKEETER

8.7 oz.	NYLON (NOT AVAILABLE '50-'51 SEASON)	\$	
8 oz.	EGYPTIAN COTTON		95.
10 oz.	EGYPTIAN COTTON		100.
12 oz.	EGYPTIAN COTTON		105.
10 oz.	ARMY DUCK		78.

8 oz.	YANKEE CLASS EGYPTIAN COTTON	\$	90
-------	---------------------------------	----	----

8.7 oz.	NYLON (NOT AVAILABLE '50-'51 SEASON)	\$	
8 oz.	EGYPTIAN COTTON		85.
10 oz.	EGYPTIAN COTTON		90.
10 oz.	ARMY DUCK		64.

6 oz.	60 SQ. FT. CLASS DOMESTIC COTTON	\$	55.
7 oz.	EGYPTIAN COTTON		65.

WRITE FOR QUOTATION ON SPECIAL SAILS

PRICES SUBJECT TO CHANGE WITHOUT NOTICE

9

JOYS BROS. CO.

1. LIGHT WEIGHT
2. LARGE SHEAVE
3. UNIVERSAL ACTION
4. LARGE THROAT
5. LARGE CAPACITY
6. CLOSE COUPLED

FRONT STEERING FORK
107 ALUM. 8.50 BRZ. 10.50

MAINSHEET BLOCK
322 5.25 EA.

WHISKER STAY TANG ON R.P.
312 .70 EA.

WHISKER STAY TANG ON HULL
312 a .60 EA.

SHEET BLOCK
323 3.50

TRACK
394 2.00

UNIVERSAL COUPLING
398 .65

BOOM SWIVEL
397 .90

GOOSENECK (WITHOUT TRACK)
396 4.50

JOYS GOOSENECK COMPLETE
395 6.50

AIRCRAFT SHACKLE
318 317 .30

TUNNEL TRACK FOR MAST OR DECK
ALUM. 318 317 .30

SPECIFY LENGTH WHEN ORDERING
5'-5.00
10'-10.00
15'-15.00

ROPE CAPACITY UP TO 1/2"

UNIVERSAL JOINT

ALUM.

Prices Subject to Change Without Notice